

HEAT RECOVERY UNIT





BREATHE CLEAN AIR SMART CONTROLLED VENTILATION WITH AIR TEMPERATURE CONTROL

Frequent ventilation of the apartment can cause the dispersion of significant amount of heat. The solution from ERA Group — the heat recovery unit CUPER. CUPER will help you to breathe clean air indoors without thinking about heat loss. The heat recovery unit filters the air, removing dust, pollen and other allergens from it. The heat recovery unit installed in the heat exchanger controls the temperature of the incoming air and makes it comfortable, so there is no need for ventilation, heating and cooling costs are reduced.



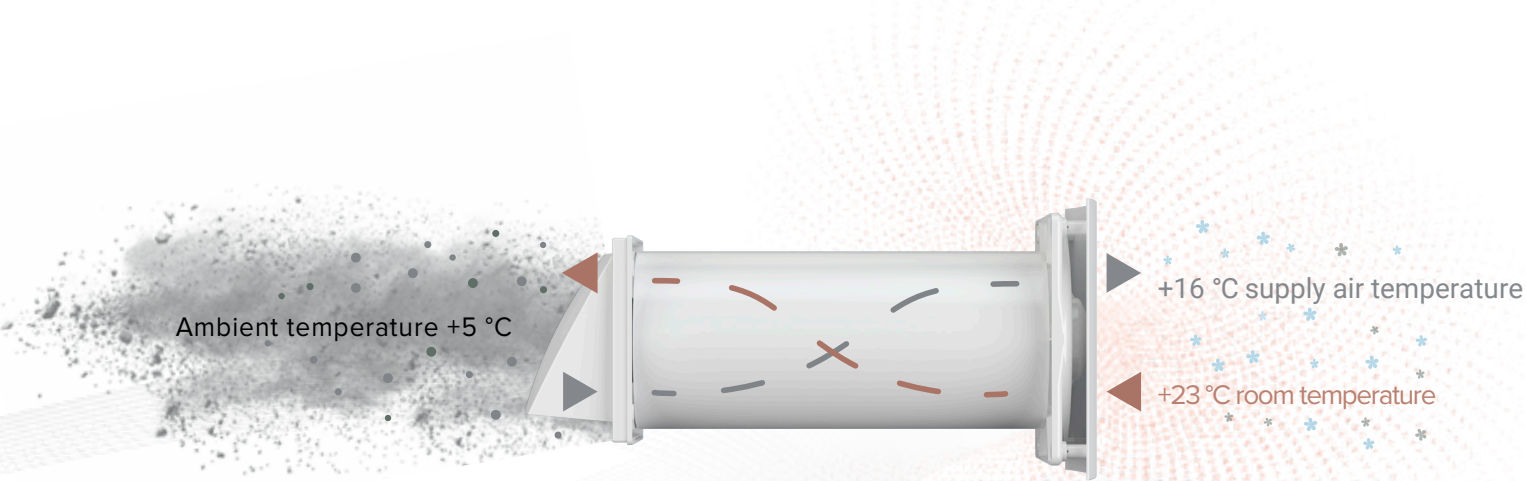

CUPER guarantees the flow of fresh air with a comfortable temperature in every season of the year. In winter, when the heat recovery unit is working on the exhaust, the air discharged from the room heats the ceramic heat exchanger. When the heat recovery unit is operating for inflow, cool fresh air is heated to a comfortable temperature. In summer, there is the reverse process: the supply air enters the room slightly cooled.

Operating temperature: from -30 °C to +50 °C. Room temperature: from +1 °C to +40 °C.

TECHNICAL CHARACTERISTICS

Six-speed heat recovery units are manufactured by the company in accordance with TS 29.32.30.261-009-96059883-2023, applicable norms and standards. Heat recovery units are designed for connection to AC network with voltage 220-240 V with frequency 50/60 Hz. Appearance, overall and connecting dimensions are shown in Pic. 1 and Table 1.

| Modification | Product name |
|--------------|---|
| Cuper 125 | Heat recovery unit Cuper. Controlled by remote control. |

| Characteristics | CUPER 125 | | | | | |
|---|-----------|-----|-----|-----|-----|-----|
| speed | 1 | 2 | 3 | 4 | 5 | 6 |
| Capacity / air supply (m ³ /h) | 20 | 34 | 45 | 55 | 63 | 70 |
| Capacity / air exhaust (m ³ /h) | 16 | 26 | 35 | 43 | 50 | 56 |
| Capacity / recuperation (m ³ /h) | 9 | 15 | 20 | 25 | 28 | 32 |
| Pressure / air supply (Pa) | 12 | 24 | 35 | 49 | 59 | 76 |
| Pressure / air exhaust (Pa) | 7 | 11 | 18 | 24 | 30 | 36 |
| Sound pressure level at a distancel 3 m / air supply (dBA) | 20 | 22 | 25 | 27 | 29 | 30 |
| Sound pressure level at a distancel 3 m / air exhaust (dBA) | 22 | 24 | 27 | 30 | 31 | 35 |
| Power consumption (W) | 1 | 2,3 | 3,3 | 5,1 | 6,9 | 9,4 |
| Recuperation efficiency (%) | to 82 | | | | | |
| Net weight (kg), no more than | 2+-0,1 | | | | | |

Table 1.

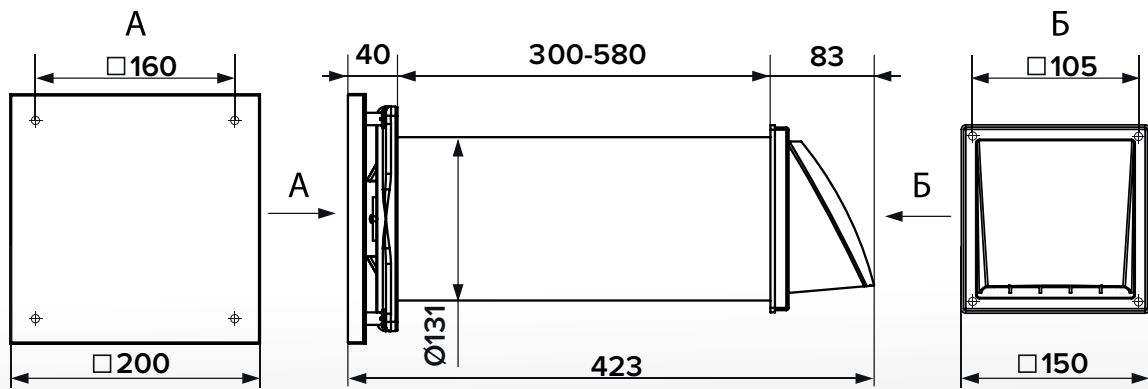

CONFIGURATION AND OPERATING PRINCIPLE

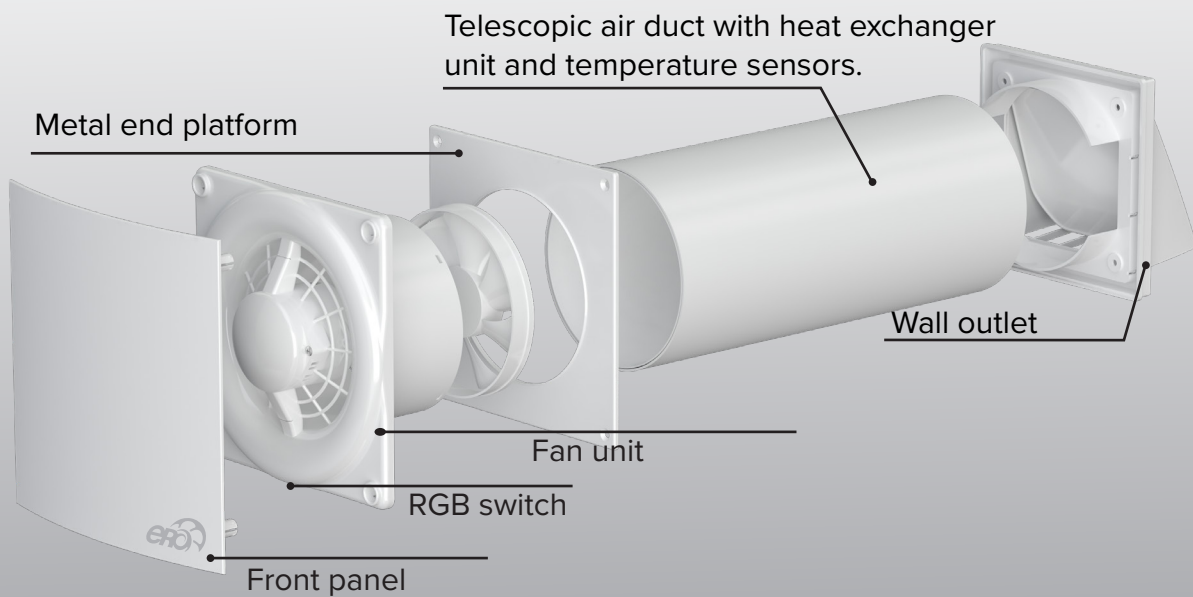

CUPER

Has four modes of operation:

4 modes



constant inflow

The fan constantly works on an inflow.



permanent exhaust

The fan constantly works on exhaust.



recuperation, alternate inflow-exhaust

Switching between inflow and exhaust every 60/70/80/90 seconds (adjusted using a switch located on the control board under the heat recovery unit housing cover).



Switching delay

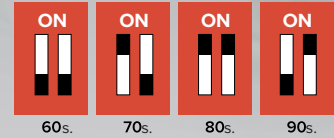

In an automatic mode, when turned on, the heat recovery unit draws air out of the room. At the end of the set switching time (60, 70, 80, or 90 seconds) there is the automatic switching inflow. At -15°C outdoor temperature of, the +10°C air will be inflown.

The inflow, as well as the, continues for a set time. Then there is a switch to the draft.

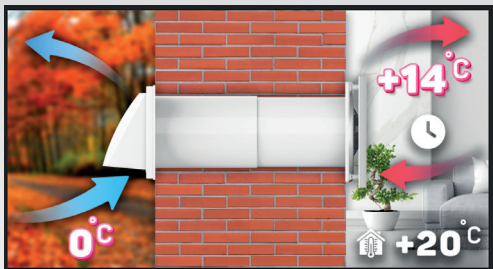

In an automatic mode, when turned on, the heat recovery unit draws air out of the room. At the end of the set switching time (60, 70, 80, or 90 seconds) there is the automatic switching inflow. At 0°C outdoor temperature of, the +14°C air will be inflown. The inflow, as well as the, continues for a set time. Then there is a switch to the draft.



Smart mode

Operating principle: heating or cooling of the ceramic heat exchanger to room temperature during exhaust and then the entry of air at comfortable temperature into the room. Thus, operation in smart mode depends of external temperature: the colder or warmer it is outside compared the room, the less the device works on the inflow. Adjustment to the inflow-exhaust is carried out by temperature sensors.

REMOTE CONTROL

The heat recovery unit is controlled by a remote control.

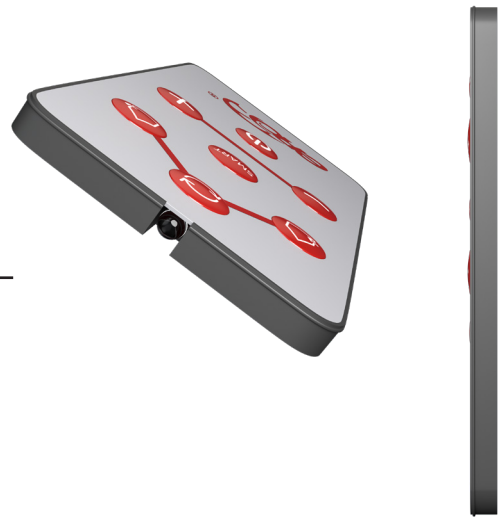
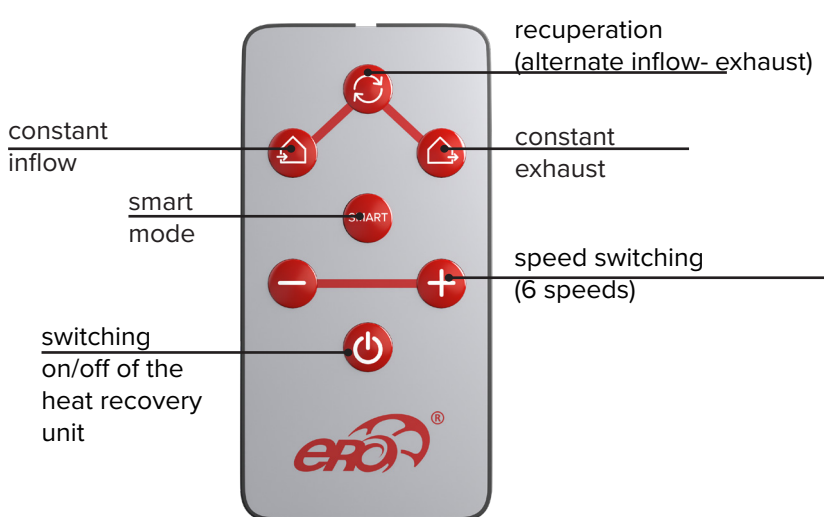

MOUNTING AND PREPARATION FOR OPERATION

ATTENTION! Before starting work, the remote control must be removed from the package and the transparent protective film must be taken off from the power compartment.

ATTENTION! Please, read the user manual carefully before mounting the product. Do not cover the reversible fan with materials that accumulate dust (curtains, etc.) to avoid disturbing the air circulation in the room.

INSTALLATION AND PREPARATION FOR OPERATION

The heat recovery unit is designed for wall mounting.

The vertical and horizontal tolerance of the mounting surface is $\pm 0,5$ mm.

The designation of the automatic protection S1 is in the diagram

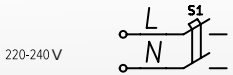

220-240V

Automatic protection S1



Connection of the heat recovery unit (basic model)

X – terminal block, 2 pairs

Electrical connection diagram

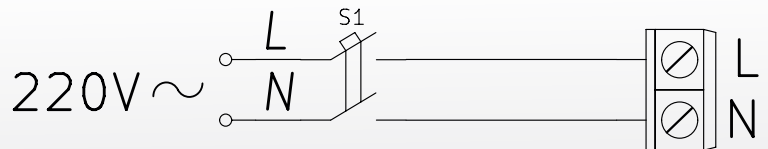

MAINS CONNECTION DIAGRAM

The fan connection to the mains is shown in Pic. 1

- remove the decorative front panel
- remove the protective cover
- lead the mains wire through hole 1 in fan housing
- remove the insulation of wires at a length of 7-8 mm
- connect the phase wire to terminal L, neutral wire (or neutral wire) to terminal N, clamp them with screws in the terminal block
- secure wires with clamp 2
- install the protective cover in place, secure with X screws
- install decorative panel

Pic. 1 CUPER

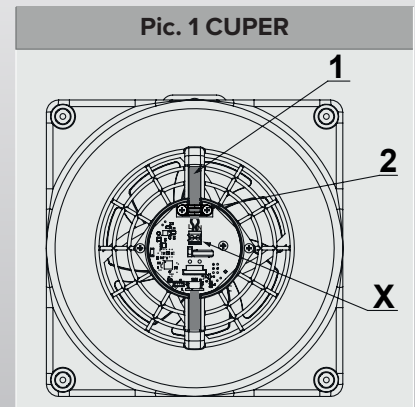

MOUNTING

Warning! Before mounting the product, you must first prepare the outlet of the power cable above the hole in the wall!

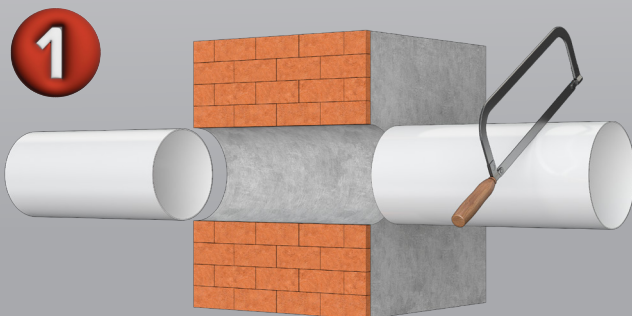

Make a hole in the wall. For drilling, use a bit with 132mm diameter of housing. The result is a 133 mm hole. Install the drilling rig, ensuring the angle of the drilling axis is 2-3 degrees towards the outside of the wall. It is necessary for the outflow of condensate to the street.

Push apart the telescopic duct before calculating the required length. You can cut the pipe to the thickness of the wall, if it's necessary. It is recommended to install the valve 20-30 cm from the edge of the window, at a height of 2-2.5 m.

On the street side, secure the external wall outlet using the fasteners and mounting template from the supplied package.

Attach a cardboard template from the street side (see the insert inside the box). The large hole in the template must be coaxial with the air duct. It is also recommended to use the construction level for horizontal alignment.

Then mark the places to install the dowels from the fastener set and drill the holes to the required depth. Install the external wall outlet by fixing it with the screws from the supplied package.

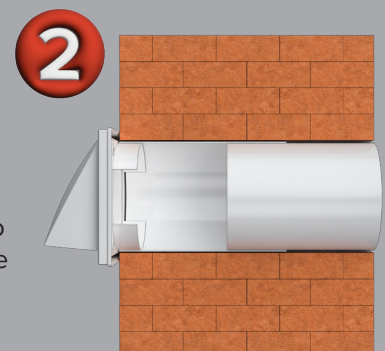

3

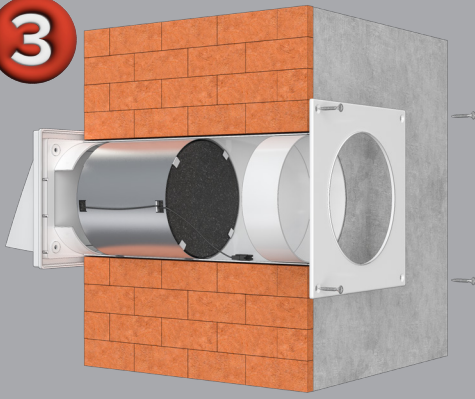

From the side of the room, install the heat exchanger unit into the duct with the cable down.
Install the metal end platform using the fasteners and mounting template from the supplied package. From the side of the room, attach a cardboard template (see insert inside the box). The large hole in the template must be coaxial with the air duct. It is also recommended to use the construction level for horizontal alignment.

Then mark the places to install the dowels from the fastener set and drill the holes to the required depth. Install the external wall outlet by fixing it with the screws from the supplied package.

4

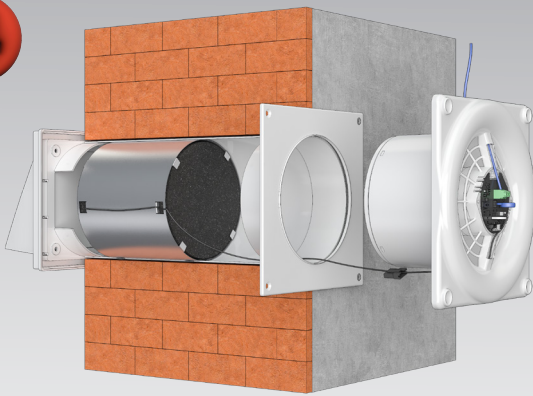

Connect the connector from the heat exchanger unit to the wire from the fan unit board, from the bottom of the housing. Insert the mains wire into the hole on top of the fan housing. Then, make a connection, according to the mains connection diagram (Pic. 1). Install the unit.

Install the fan unit with magnets built into the housing on the metal end platform.
Insert the front panel.

5



You can glue wallpaper to the front panel so that the heat recovery unit looks seamless in the interior of the room.



